

ALVO® Premium



INTERIORS OF THE FUTURE
1st Award, 2016



ALVO HYGIENE GUARD

Premium scrub sink to help prevent the spread of hospital infections

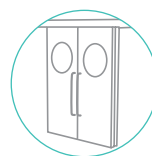
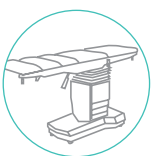

Human-oriented design

We take a human-oriented design approach when developing new medical products.

To truly understand what the top tasks of the surgical teams are when they enter the scrub rooms and how well these tasks can be performed, we use ethnographically informed research and co-design sessions. By moving design activity into the OR routine, our team has created a new modular scrub sink, calling it „a great piece of furniture which helps to prevent the spread of infection“.

ALVO® Premium



The new **ALVO Premium scrub sink** unit with superior design lines, enhanced functionality and easy to clean hygienic surfaces is the right solution for any operating theatre.

ALVO® Premium

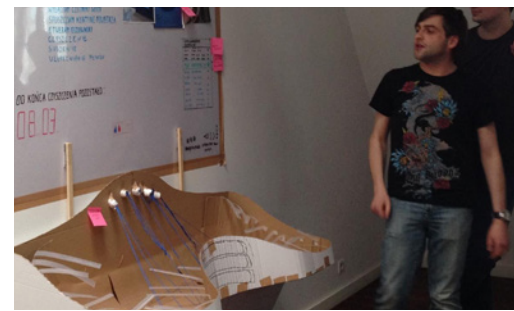
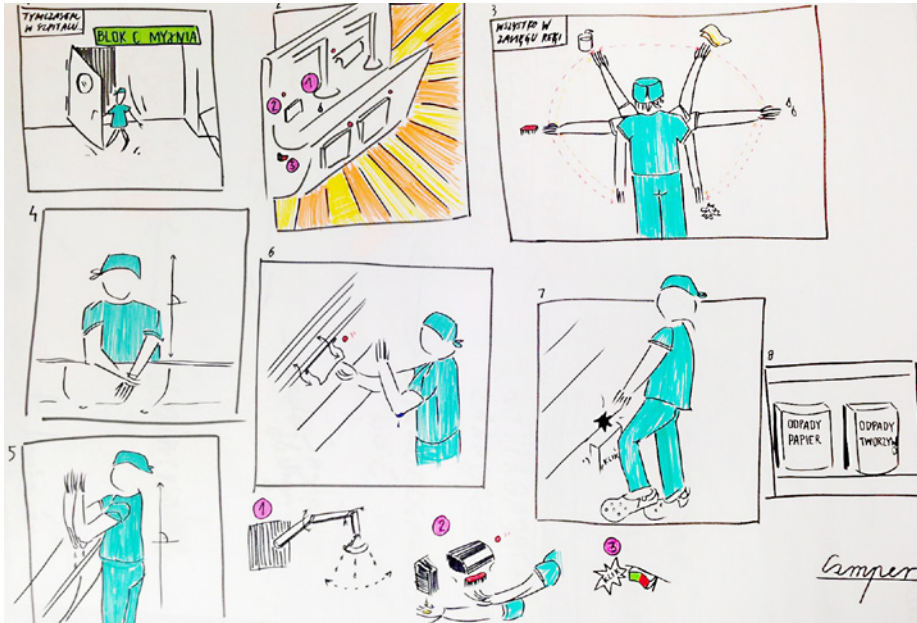

The outcomes from health hazards caused by the risks of infection, in terms of monetary and reputational costs, are enormous...

According to two WHO investigations, 20–40% of all HAIs (Hospital Associated Infections) are attributable to cross-contamination; in other words, the pathogens are transmitted from one person to the next. Hand hygiene plays an elementary role here – **experts estimate that 70–80% of all infections are transmitted via the hands.**

Alvo Medical designed a solution which makes hand-scrubbing a little more fun, sophisticated, intuitive and easy at the same time. The new ALVO Premium scrub sink comes as an **all-in-one unit with touch-free operation.**

Additionally to product development, ALVO has worked with Concordia Design team to link innovation sensitivity to human-centered design. The new focus of the ALVO team will be applying insights into the needs of users: architects, clinicians and other stakeholders, as well as balancing WHO indications and business reality.



- 'Interiors of the Future' 1st Award, 2016
- i-Novo Design Awards 2015 nominee

Smart solution: Increased hygiene and safety!

The two-station premium scrub sink **solves 3 major problems** of surgical staff members:

- prevents water from splashing, keeping the floor area dry and clean
- provides all supplies and accessories built-in one unit, including drains disinfection
- enables touch-free operation for increased hygiene and liquid portions management

ALVO® Premium



ALVO Premium scrub sink | 2-096

- wall-mounted All-In-One module with accessories
 - towels, brushes and liquids dispensers build in the module, behind the mirror, with easy access ergonomic shape of the sink prevents from splashing the water
 - profiled edges allow the user for keeping comfortable, healthy position
 - easy to clean, made of impact-resistant mineral acrylic composite material with silver ions antimicrobial protection
 - ergonomic, enhances workflow, perfectly fit for small space
 - touch-free operated tap to release: water, soap and disinfectant
 - ALVO CleanDrains disinfecting siphon to enhance hygiene from the inside*
-
- measurements: 1600 x 695 x 1600 (mm)
 - weight: ca. 130 kg
 - supplies: 230 V/ 50Hz

*not included in the price of the product

Discover the new hand scrubbing experience during our workshops:

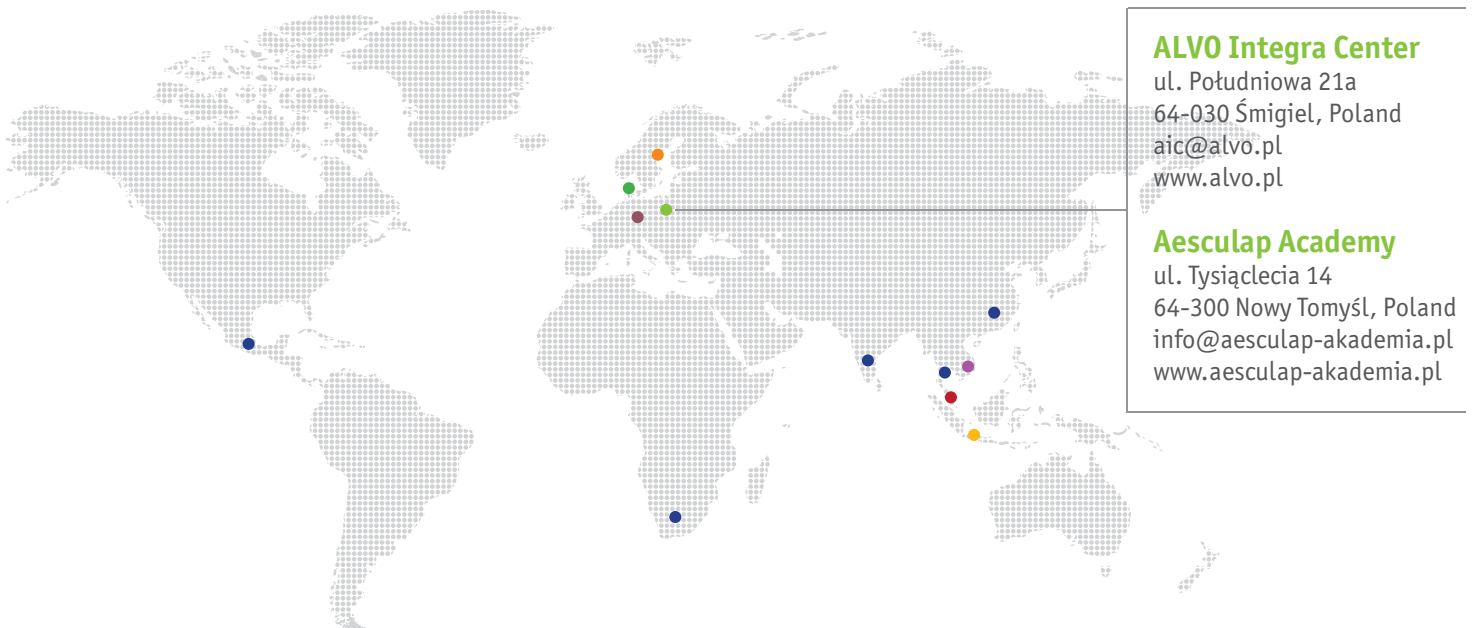

ALVO® Premium

Water, soap and disinfectant tap - 3 in 1

Safer. Cleaner. More Hygienic.

The clever 3 in 1 design eliminates the need for frequent cleaning as any hand hygiene products dripping from the user's hands are neatly contained in the sink resulting in no messy puddles for safer, cleaner and more hygienic facilities.

Intuitive User Interface

A completely touch free experience. It's as simple as moving your hand over the indicated section of the glass display to activate the product you want. The coloured LED light signals will show which product has been activated. To receive the product you have activated, simply place your hand under the faucet.

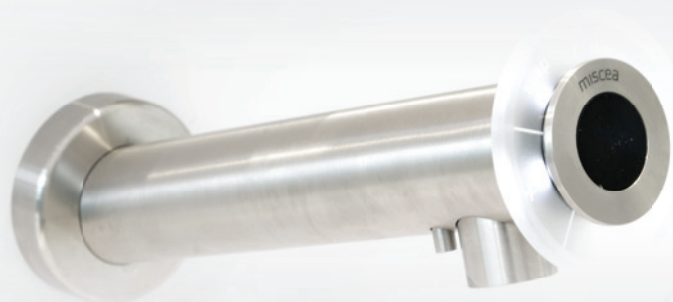

Achieve Optimal Hand Hygiene

For optimal hand hygiene, the World Health Organisation has recommended the use of sensor activated faucets and dispensers as the ideal standard within health-care settings.

Safety Feature Against Bacteria

The CLASSIC system has an inbuilt safety feature against bacteria. It will automatically run a cleaning cycle, flushing water and both liquid dispensers to prevent harmful waterborne bacteria growth usually found in stagnant water. These cleaning cycles can be programmed to the desired frequency with the handy miscea remote control.

Save Water by up to 60%

Miscea Sensor faucet systems can lower water usage by up to 60%*. It works by ensuring water flows only when you really need it and automatically shuts off when you don't. Special aerators integrated into miscea faucets also help to reduce water consumption by enriching the water with air, resulting in a luxurious stream of bubbly water that is soft to the touch, non-splashing while using even less water.

* Compared to manually operated faucets without water saving aerator: 3.5 gpm

Performance Specifications

Voltage	24 V _{DC}
Input Voltage	100 ~ 240 V _{AC} / 50~60 Hz
Operating water pressure	0,8 - 10 bar
Max. water temperature	75°C
Enclosure rating of PCB	IP 55

Faucet weight (incl. hoses & cables)

Standard model:	1,0 kg
Wand model:	0,9 kg
Water box weight (incl. hoses)	1,75 kg
Soap box (excl. pouches)	0,95 kg

Default Settings

Response time of water flow stop	1 sec
Dispense volume of soap	1 ml
Dispense volume of disinfectant	3 ml

Faucet Dimensions

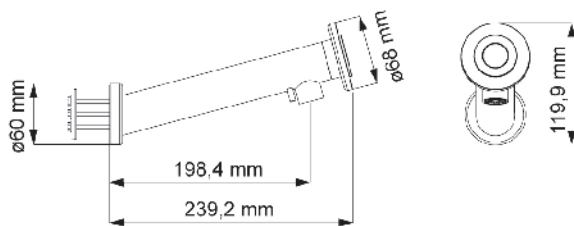

MISCEA WALL FAUCET

Waterbox and Soapbox Dimensions

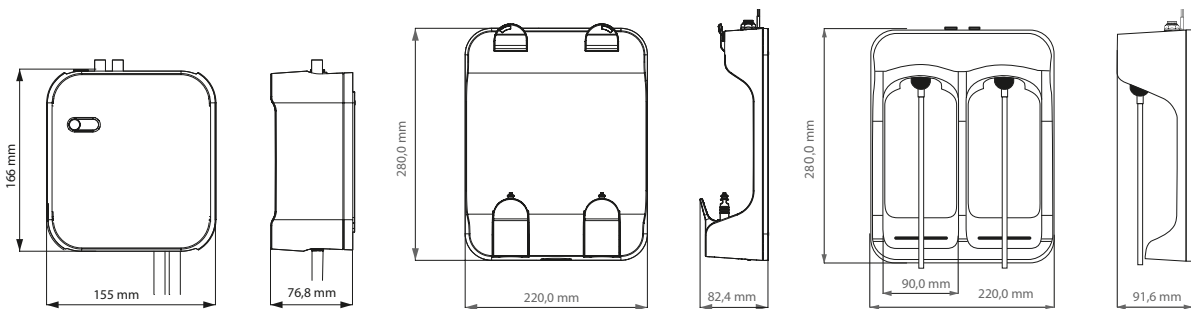

WATERBOX

SOAPBOX POUCH

SOAPBOX BOTTLE

With increased hygiene and patient safety on minds...



ALVO® Premium



ALVO® Premium

Technology and design

Combining user-friendly design with touch free operation and accessories and waste management supports the best hand scrubbing techniques. It increases the comfort of all surgical team members, enhances hygiene and costs saving. An infection-free hospital is a trusted hospital!



Ergonomic shape of the sink with antimicrobial protection by Sanitized.



Small details that make the big difference

The sink is made of lightweight, non-porous composite material with silver-ions additive Sanitized®. The Swiss technology Sanitized® helps to reduce the growth and spread of microorganisms that are particularly problematic such as clostridia and antibiotic-resistant bacteria such as MRSA, VRE and NDM-1. The Sanitized® technology is based on active ingredients that are added to the ALVO Premium scrub sink during manufacturing, giving it reliable protection against microbes even between cleaning cycles.

discrete and smart storage of all accessories and dispensers hidden behind a mirror panel, allowing easy access

wide, rounded edges to prepare sterile towels

removable shelf for waste brushes inside the sink

knee-activated drawers with waste bins

automatic drains disinfection

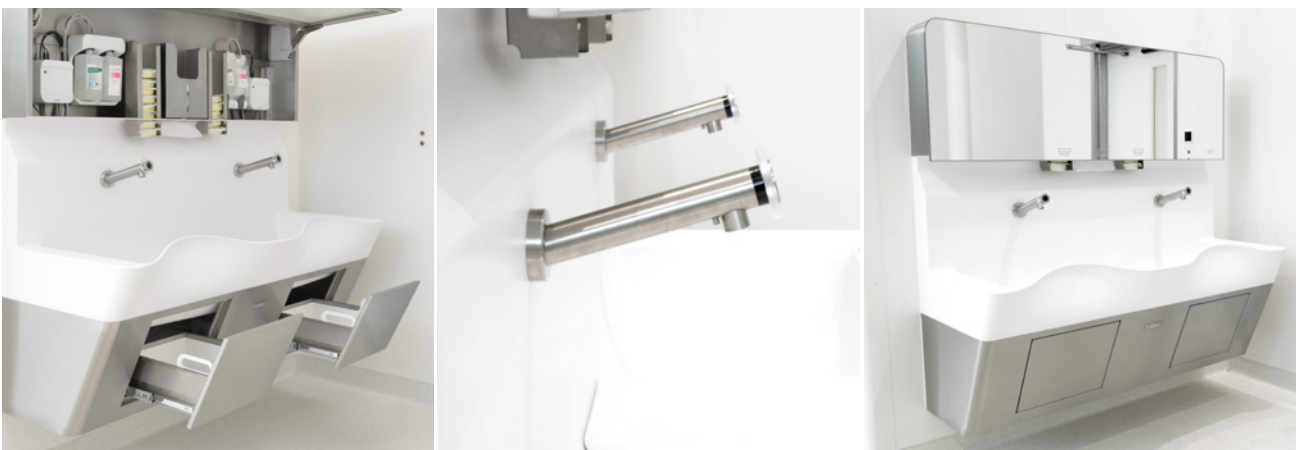

The backlighted icons on the mirror inform about the current operating status of the device.



Constant operation (green highlighted)

The device is switched on (24 V supply is available).
The device is ready for operation.



Disinfection (green highlighted)

When the "DISINFECTION" LED lamp is lit, the heating for the disinfection is in operation. The "DISINFECTION" LED lamp remains lit until the required temperature has been reached in the disinfection unit.



Cleaning (green highlighted)

The "CLEANING" LED lamp lights up for several minutes immediately after the maximal temperature for disinfection has been reached.



Fill level (yellow highlighted)

When the "FILL LEVEL" LED lamp is lit, then the minimum level has been reached and the disinfection is complete.
The device is in inactive mode!

The **ALVO® CleanDrains** is a CE-certified disinfection system for sink drains in clinical sanitary areas. Bacteria in the drain can escape with the aerosol excited by the running water, rising to a height of up to 1.5 meters. This poses a threat not only to medical personnel, but also to patients, who are therefore at risk of developing the hospital-acquired infections (HAI). **ALVO® CleanDrains** automatically cleans and disinfects liquids in siphons under the scrub sink, regularly during use. Thanks to this, the risk of pathogens appeared in the scrub sink when draining the water or emptying the sink is completely eliminated.

Drains disinfection of **ALVO® CleanDrains** is based on the following functional processes:

- continuous physical-thermal disinfection between 85°C and 93°C,
- electromechanical vibration cleaning of the inside walls of the siphon - ca. 50 Hz.

In the process the unit heats up to the set temperature (85°C) and slowly cools down while the subsequent vibration cleaning takes place. Once the minimum set temperature has been reached (75°C), the heating process and thus the disinfection cleaning cycle recommences once again. If no interruption is caused by additional water inflow, then the entire process is completed after 5-6 cycles in a period of approximately one hour and **ALVO® CleanDrains** switches into standby mode until water flows in again.

The results of a study¹ published in the Journal of Hospital Infections in 2019 show that the dangerous antibiotic-resistant pathogen *P. aeruginosa* (**MDR-PA**) was successfully eliminated after the installation of the self-disinfecting **ALVO® CleanDrains** siphon in scrub sinks. The research was conducted in two intensive care units at a hospital in Leiden, the Netherlands. Bacterial colonization decreased from 51% and 46% to 8% and 2.4%, respectively. The proportion of HAIs decreased during this time, in turn, from **8.3% to 0% and from 2.7% to 0.5%** per 1,000 patients.

The research results clearly show that the **ALVO® CleanDrains** siphon significantly increases the safety of patients and medical staff in the operating theater.

More information: <https://blog.alvo.pl/>

¹ E. de Jonge et al.: Effects of a disinfection device on colonization of sink drains and patients during a prolonged outbreak of multidrug-resistant *Pseudomonas aeruginosa* in an intensive care unit, Vol. 102, Issue 1, p. 70-74, May 01, 2019

ALVO Medical Sp. z o.o.
ul. Południowa 21a
64-030 Śmigiel, Poland
tel. +48 65 518 98 49
fax +48 65 518 98 56
www.alvo.pl

